

ANNEXE B

SCHEMAS ET MESURES IRC

TYPES DE QUILLE

Sélectionnez la quille qui se rapproche le plus de celle de votre bateau.

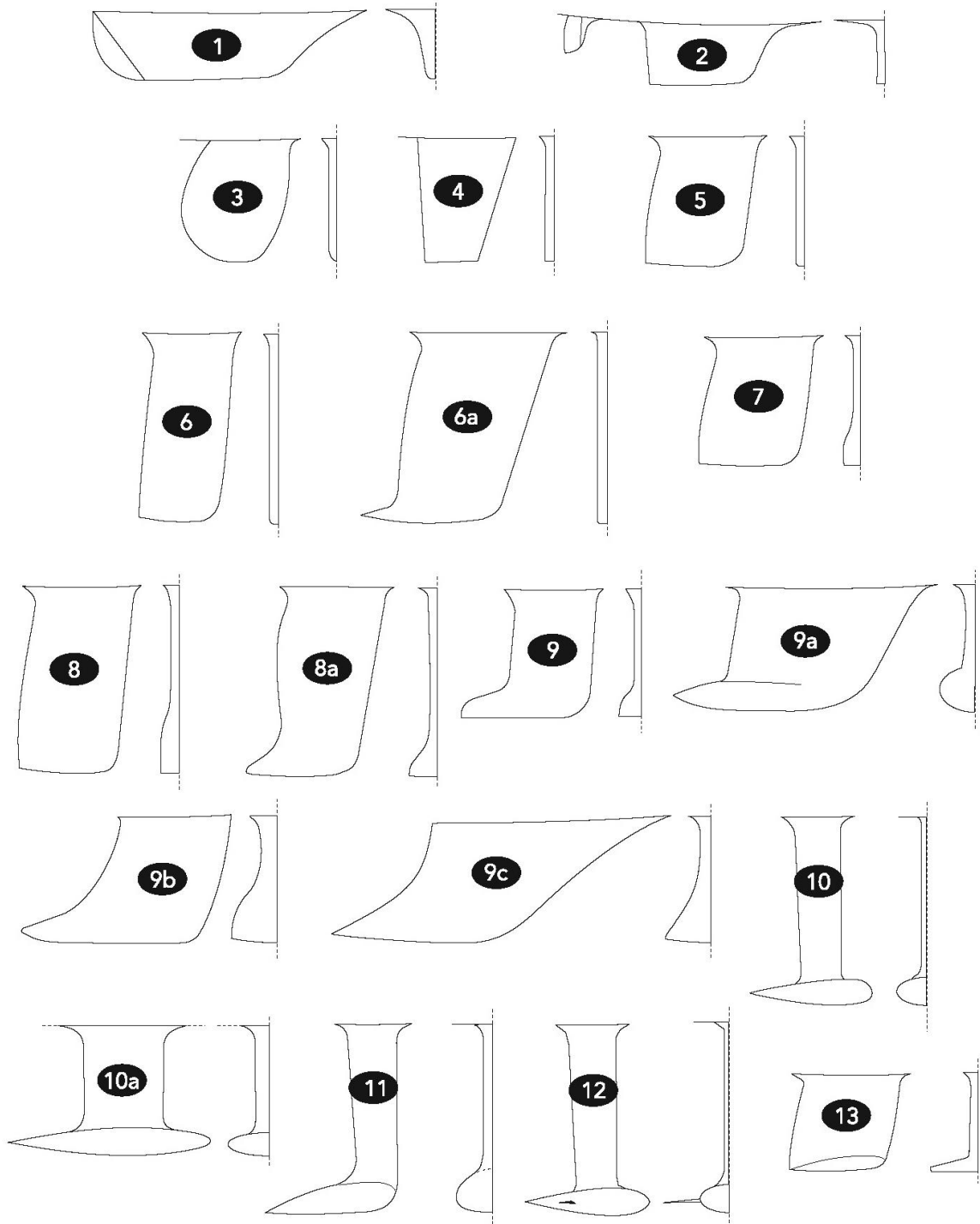

QUILLE PIVOTANTE

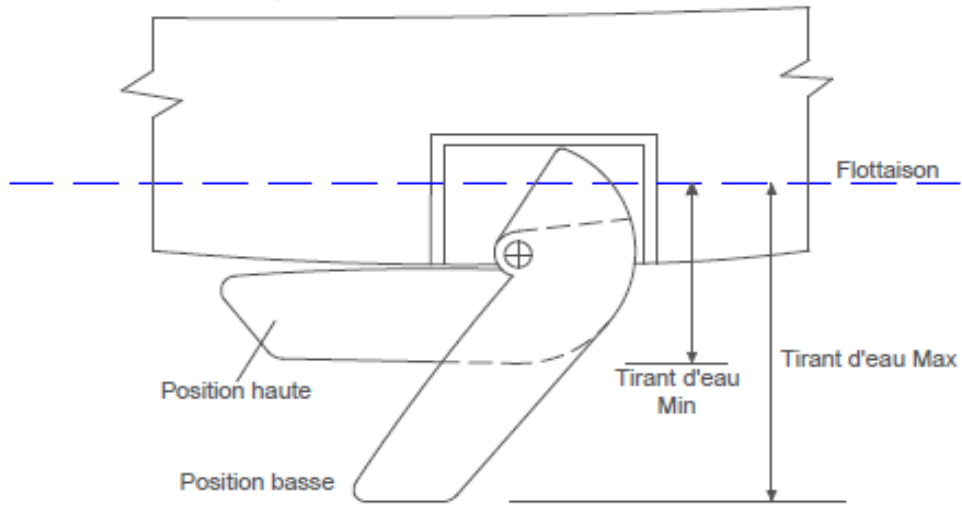

DERIVE PIVOTANTE

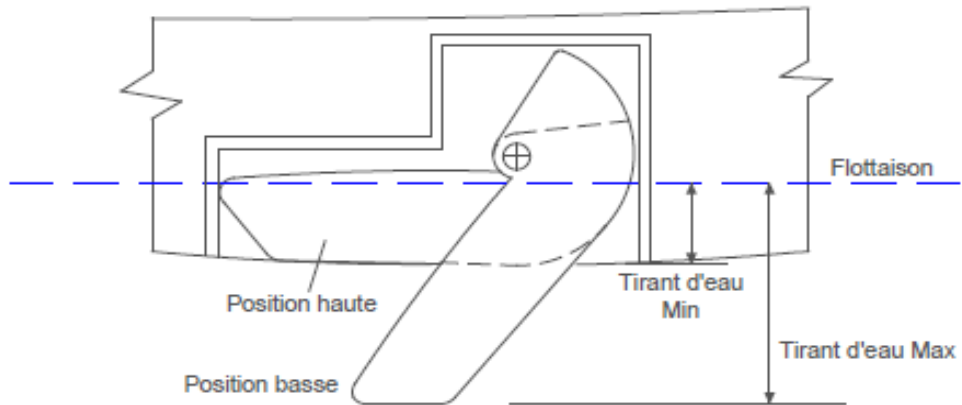

DERIVE SABRE

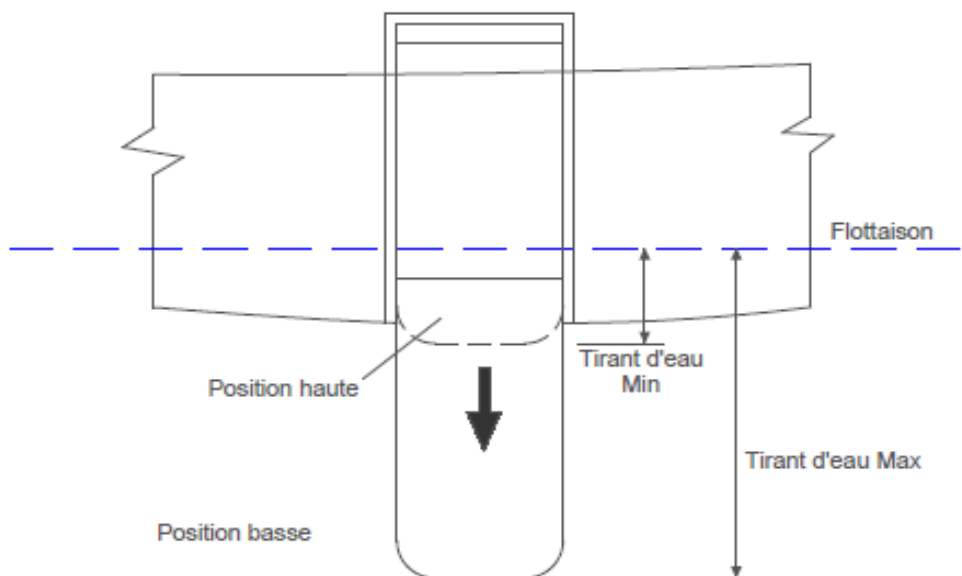

Sur votre demande de certificat, indiquez si la quille est fixée en position basse *en course*.

ELANCEMENTS, FLOTTAISON

ELANCEMENT AVANT

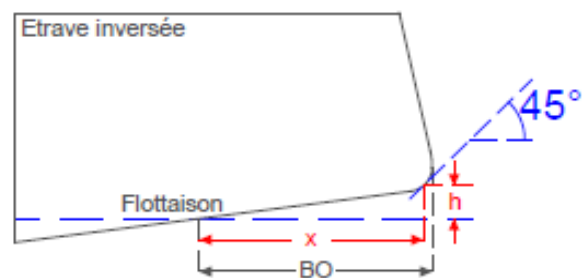
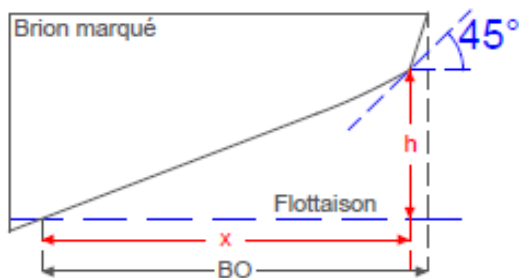
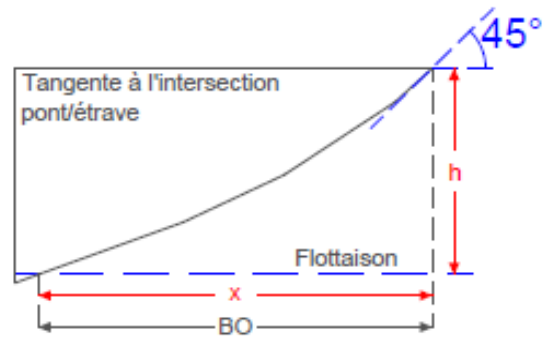
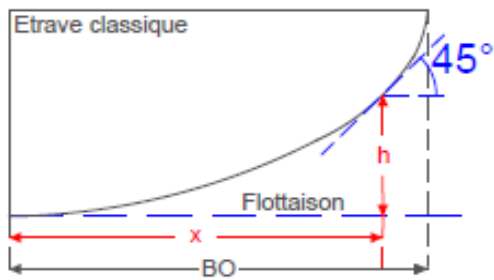
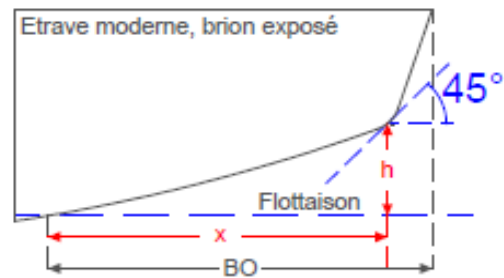
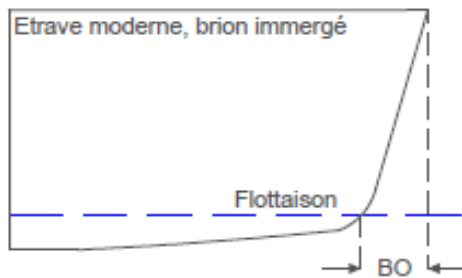

ELANCEMENT ARRIERE

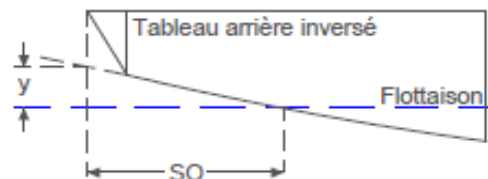
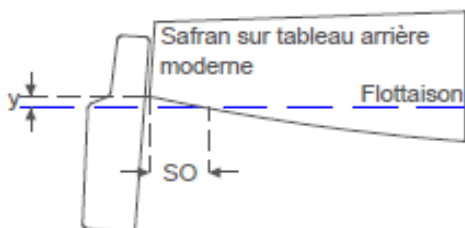
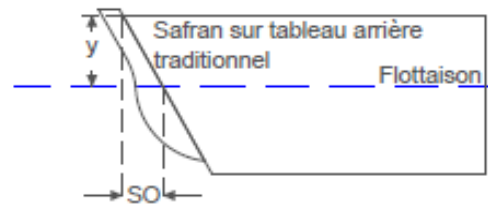
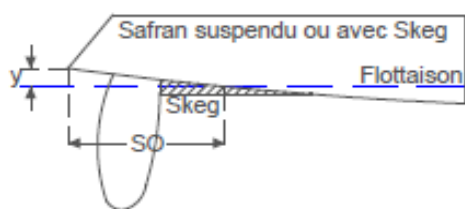

J, SPL, STL, VOILES

J, SPL et STL

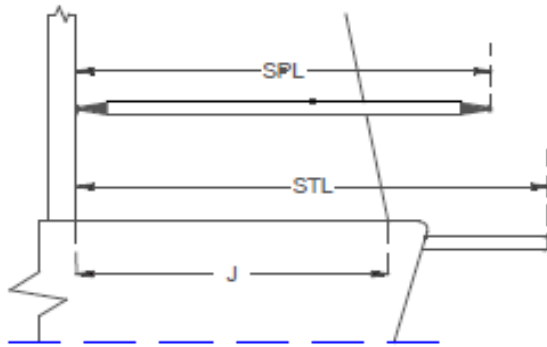

GRAND-VOILE (largeurs)

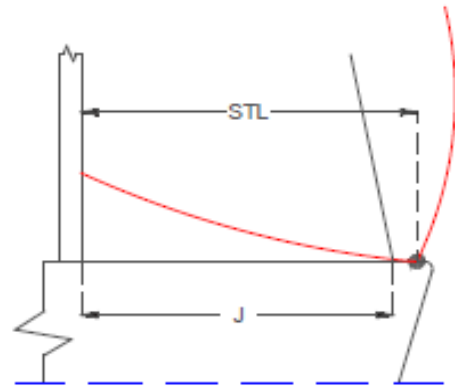

VOILE D'AVANT

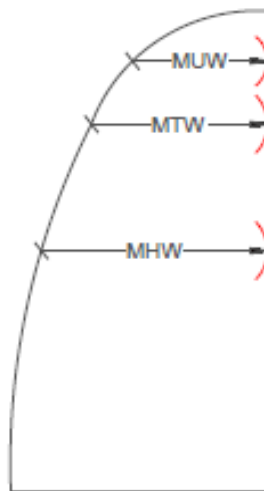

SPINNAKER

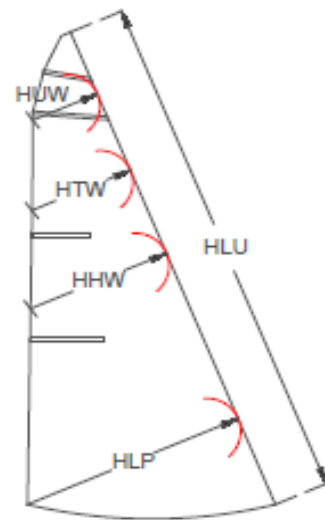

GENOIS VOLANT

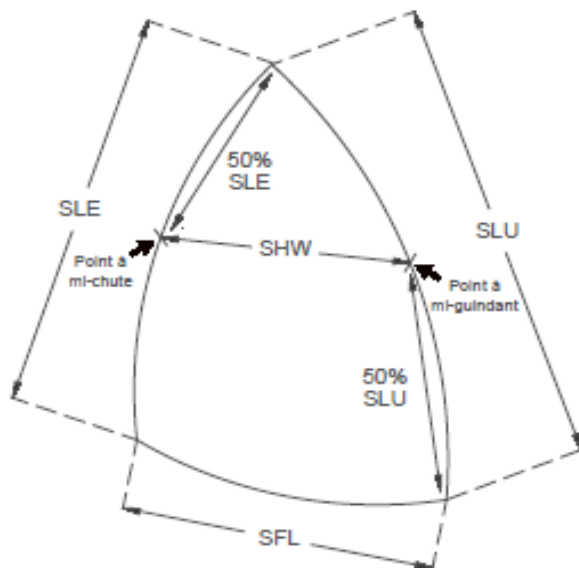

$SHW \geq 75\%SFL$

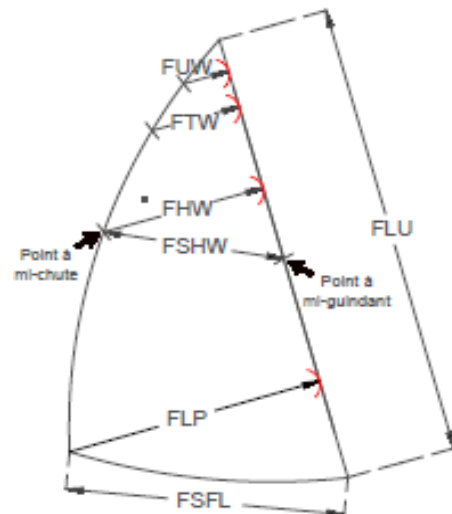

$FSHW < 75\%FSFL$
ET $FSHW \geq 60\%FSFL$

GREEMENTS

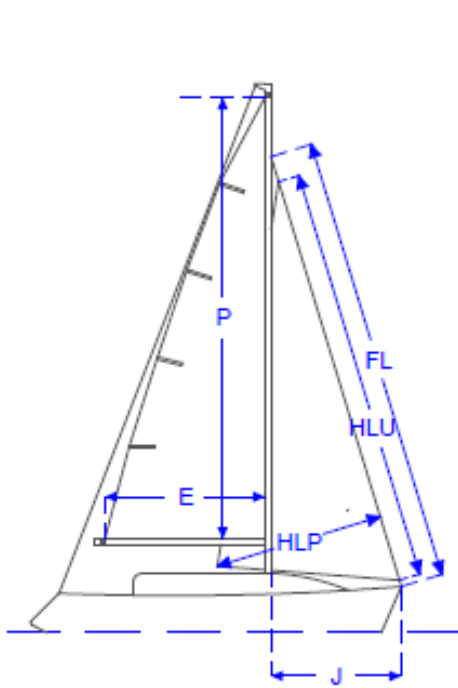

SLOOP

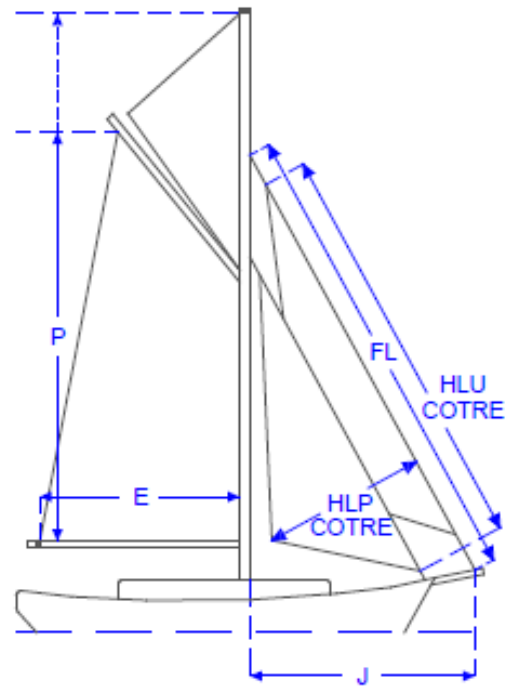

CÔTRE

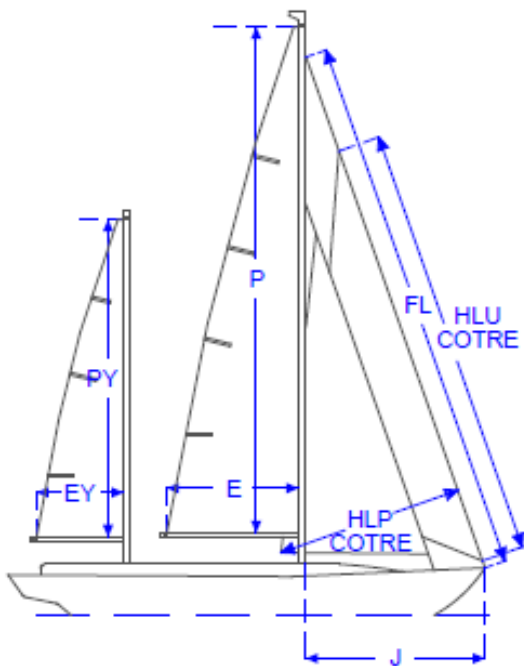

KETCH

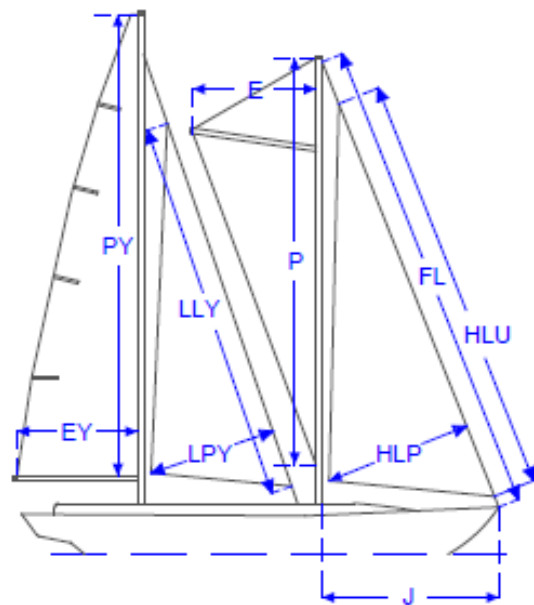

GOELETTE

GREEMENT ARRIERE

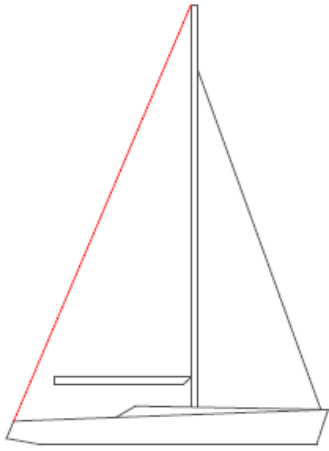

1 ETAI/GROUPE D'ETAIS

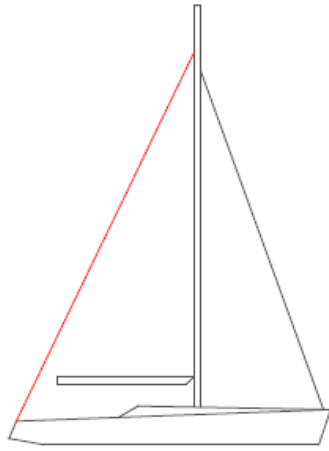

1 ETAI/GROUPE D'ETAIS

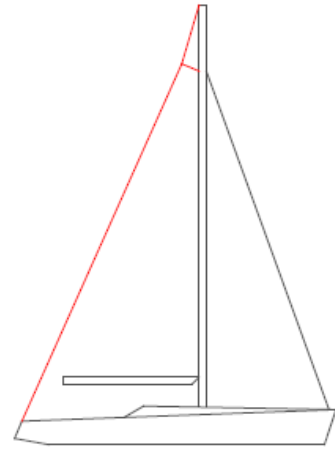

2 ETAIS/GROUPES D'ETAIS

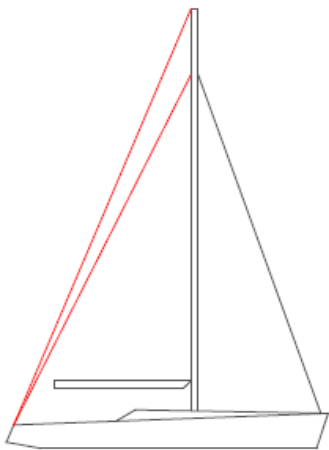

2 ETAIS/GROUPES D'ETAIS

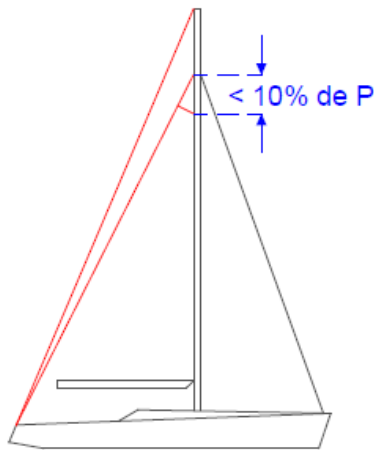

2 ETAIS/GROUPES D'ETAIS

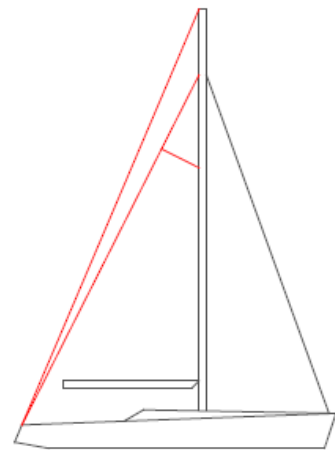

3 ETAIS/GROUPES D'ETAIS

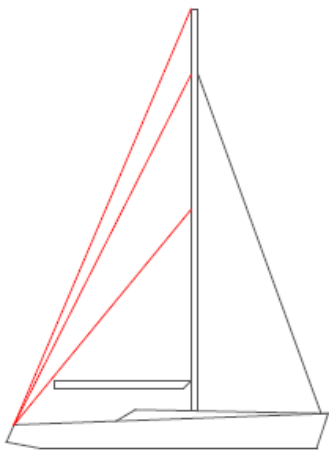

3 ETAIS/GROUPES D'ETAIS

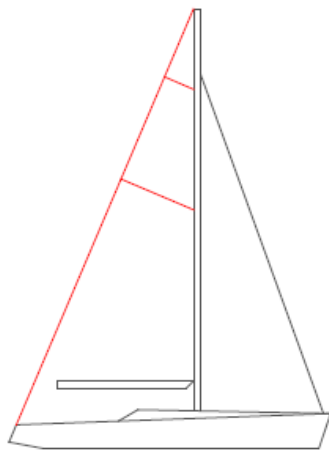

3 ETAIS/GROUPES D'ETAIS

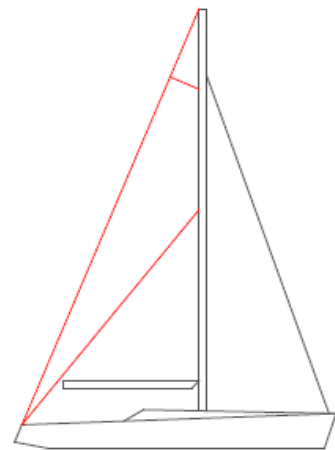

3 ETAIS/GROUPES D'ETAIS